

winflex®

Flexible grid coupling





Winflex couplings:

the best cost-effective and reliable solution, years of use to achieve and to prove this fully optimised coupling!

The hub

- Thanks to the very special design of the teeth, the contact surface between the grid and the hub teeth increases proportionally to the torque to keep the same contact pressure at any time.
- As contact is on numerous teeth, this efficiently absorbs the torque thus avoiding damage.
- No resulting reaction forces on shafts.

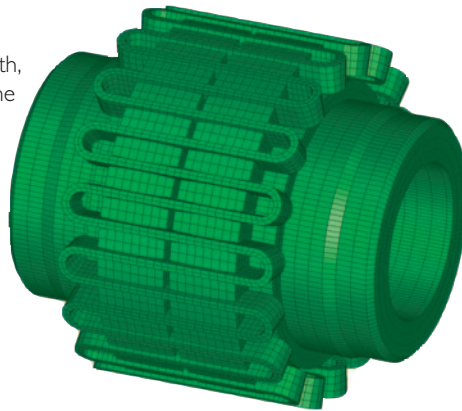

The grid

- The grid always works in the direction of the material, within its elastic field.
- A new surface treatment prevents oxidation, friction and wear.
- The grid has been manufactured to ensure durability.

Normal load

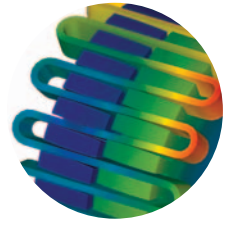

Heavy Shocks

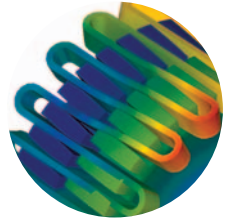

and Excessive Overloads

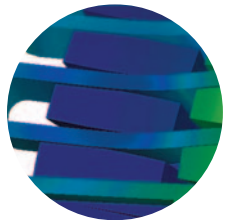

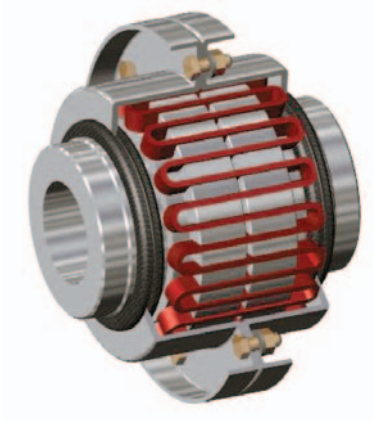

A complete range!

Only one grid for each execution of the same size

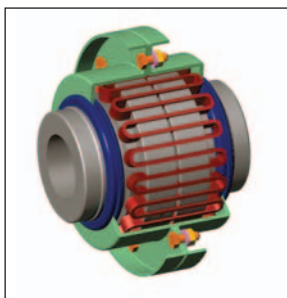

T.TL.TL2

Vertical or Horizontal Position

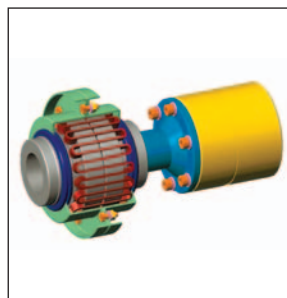

T.TL.NPE

Spacer type

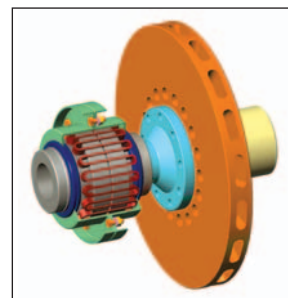

TDF

Disc brake type

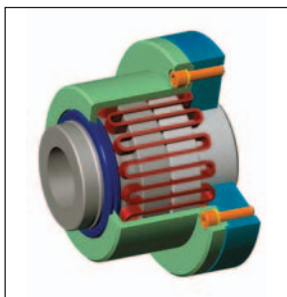

BSAT

Single cover type

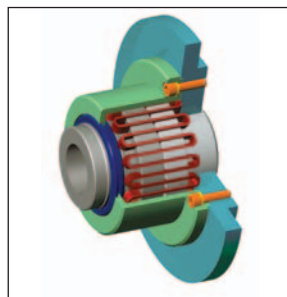

BSA

Single cover type for Flywheel, pulley application etc...

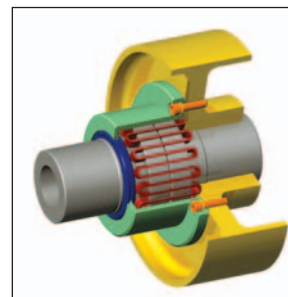

CPF

Brakewheel type

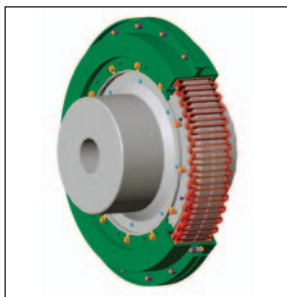

S

Heavy duty type

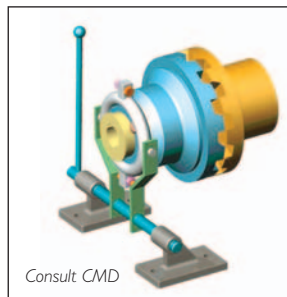

Consult CMD

Overrunning clutch

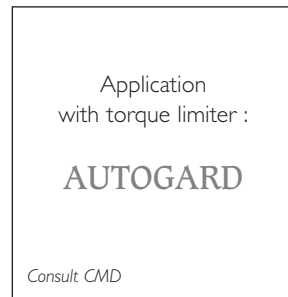

Application with torque limiter :

AUTOGARD

Consult CMD

Selection

1) DETERMINE THE CALCULATED TORQUE

$$\text{Calculated Torque (Nm)} = \text{Absorbed Torque (Nm)} \times \text{SF} = \frac{9550 \times \text{Absorbed power (kW)} \times \text{SF}}{\text{rpm}}$$

Selection of Service Factor SF: see table below.

2) SELECT

The size of coupling whose rated torque is equal or higher than the calculated.

3) CHECK

That selected coupling is compatible with speeds and bores as mentioned on the tables.

APPLICATIONS	SF	APPLICATIONS	SF
AGITATORS *	1	LUMBER INDUSTRY	
CEMENT INDUSTRY		Circular rip saw	1.75
Balls and rods	2	Ban rip saw	1.5
Hammer mill or hog	1.75	Edger, Head rig Hog	2
Grizzly	2	Log haul	2
COMPRESSORS		Rolls, reversing	2
Centrifugal	1	Trimmer	1.75
Rotary	1.25	MACHINE TOOLS	
Reciprocating (1 cylinder, single acting)	3	Miscellaneous, auxiliary*	1
“ (1 cylinder, double acting)	3	Notching press	1.75
“ (2 cylinder, single acting)	3	Planer	1.75
“ (2 cylinder, double acting)	3	Main drive	1.5
“ (3 cylinder, single acting)	3	PAPER INDUSTRY	
“ (3 cylinder, double acting)	2	Calender	1.75
“ (4 cylinder more, single acting)	1.75	Super-calender	1.75
“ (4 cylinder more, double acting)	1.75	Line shaft	1.5
CRUSHERS		Cylinder, dryer, couch, press	1.75
Minerals	2.5	Chipper	2.5
Stone	2.5	Reel, rewinder, winder	1.5
CONVEYORS		Beater, pulper	1.75
Belt/screw conveyors	1	Jordan	2
Apron conveyors	1	Barking drums (final gearing machined)	2
Scraper	1.5	Barking drums (cast teeth gear)	2
Buckets conveyors	1.25	Felt stretcher	1.25
CRANES, HOISTS, ELEVATORS*		PUMPS	
Main hoist	1.75	Centrifugal	1
Bridge, travel or trolley	1.75	Gear. Rotary or vane	1.25
Mach, tools, warehouse	2	Reciprocating (1 cyl. Dble or single act)	3
Grab-buckets, casting, scraps	2.5	“ (2 cyl. Dble act)	1.75
Filler, pits, strips, ingots	2.5	“ (3 cyl. Dble act)	1.5
Cranes for general handling	1.75	RUBBER INDUSTRY	
Cranes for harbor and grab-buckets	2.0	Calender	2
FANS		Mixer (Banbury-Werner)	2.5
Blowers centrifugal*	1	External mixer, mixing mill	2.5
Cooling tower fan	2	Super calender	2.5
Forced draft with slip clutch*	1	STEEL WORKS	
Induced draft with damper control	1.25	Draw bench, wire drawing	2
Induced draft without control	2	Coilers, uncoilers (at max.torque)	1.5
FLOUR MILLING		Strengtheners flattening	2
Various type	1.75	Wire mills	2
FOOD INDUSTRY		Rod mills	2.5
Beet slicer	1.75	Feed rolls, Blooming mills	3
Bottling, can filling mach	1	Tube conveyor rolls	2
Cookers, continuous duty	1.25	SUGAR INDUSTRY	
GENERATORS		Cane knife and crusher	2
Even load	1	Mill stands turbines driven with helical gears	1.5
With overload	2	Mill stands turbines driven with any other prime mover	2
Welder load	2	TEXTILE	
A.C dynamo with hyd. turbine*	1	Miscellaneous	1.5
		Calender, Card machine	1.5
		Printing cylinder	2
		WOOD WORKING MACH.	
		Miscellaneous	1.25

* Only Applicable to installations with Maximum Torque less than 1.5 x Coupling Basic Torque.

Type T - TL - TL2 Horizontal or Vertical Working position

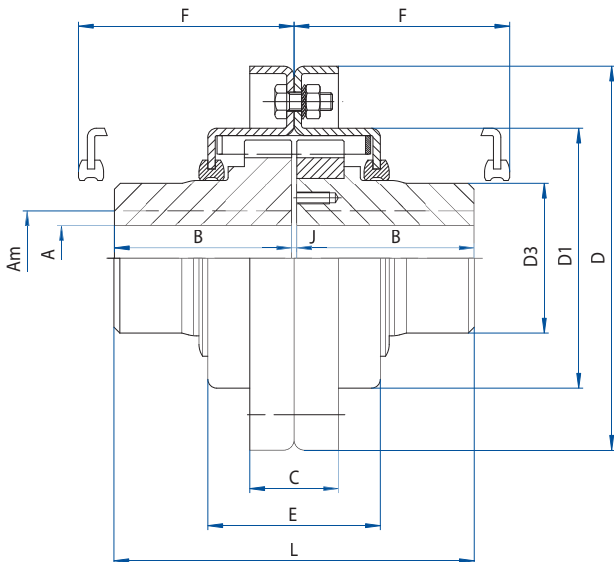

Hub Z to 16

Hub 28 to 95

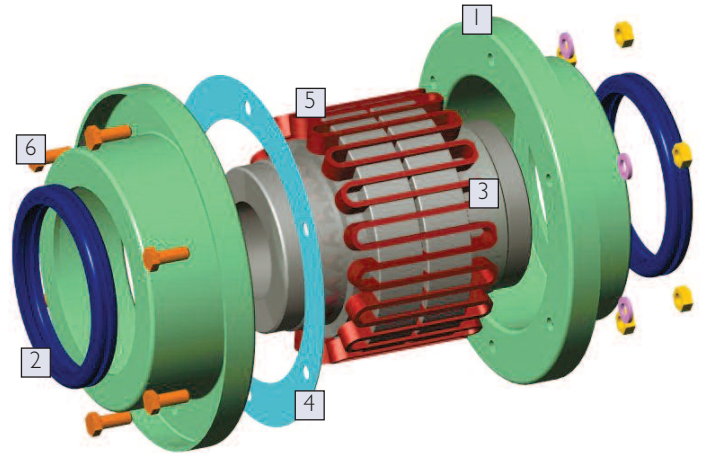

Item	Designation
1	Halfcover
2	Seal
3	Hub
4	Gasket
5	Spring
6	Bolts & Screws

F: Clearance for grid spring assembly and removal

SIZE	Z	000	00	0	1	2	5	9	16	28	43	70	95
Nominal Torque (Nm)	90	190	380	950	1900	3800	8500	12500	24000	48000	70000	120000	160000
Am	Keyway	28	38	55	55	80	110	105	130	180	230	230	270
	Shrink fit	-	-	45	45	60	100	90	110	170	200	220	250
A	Rough bore	-	-	-	-	-	30	30	60	75	85	95	105
B**	T	50	60	60	60	80	80	110	110	130	155	180	230
	TL,TL2	-	-	-	110	110	110	170	195	195	225	260	300
	C	20	30	30	30	30	36	36	42	44	50	50	50
	D	92	130	158	165	200	250	265	307	395	494	595	670
	D1	68	88	113	120	154	203	212	253	330	427	522	598
	D3	39	51	76	76	110,5	158	146	183	253	330	330	380
	E	57	58	58	77	77	78	123	123	124	125	200	206
	F	58	59	59	78	78	79	125	125	126	126	201	201
	J	2 ⁺¹ _{-0,5}	2 ⁺¹ _{-0,5}	2 ⁺² _{-0,5}	2 ⁺² _{-0,5}	3 ⁺¹ ₋₁	3 ⁺¹ ₋₁	3 ⁺¹ ₋₁	3 ⁺¹ ₋₁	3 ⁺¹ ₋₁	4 ⁺² ₋₂	4 ⁺² ₋₂	4 ⁺² ₋₂
	L (type T)	102	122	122	122	163	163	223	223	263	314	364	464

Weight type T (kg)	1.84	3.7	6.6	7.8	16.6	31	42	63	125	245	327	409	579
↓ Solid hub type T (kgm ²)	0.0011	0.0037	0.0105	0.0135	0.04	0.14	0.20	0.45	1.5	4.65	8.25	11.5	20.25
Max. speed (Rpm)	Without balance	4500	4500	3650	3450	2640	1880	1880	1570	1200	920	750	650
	Dynamically Balanced	-	-	4500	4500	4000	3600	3200	3000	2500	2000	1500	1250

**Types: T = 2 short hubs
 TL = 1 short hub, 1 long hub
 TL2 = 2 long hubs

The contents of this bulletin are subject to change without notice.

Type T - TL NPE

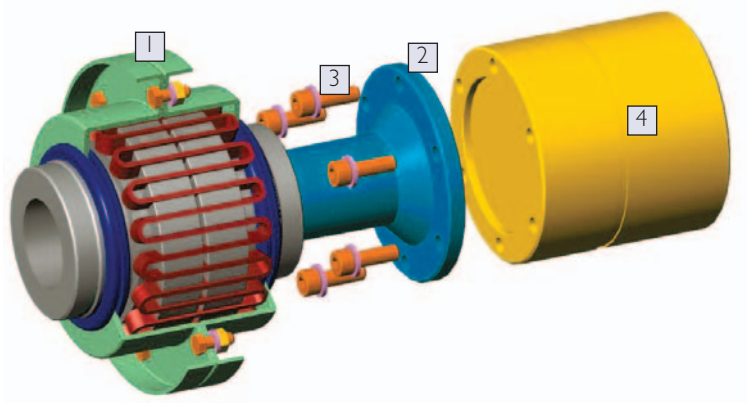
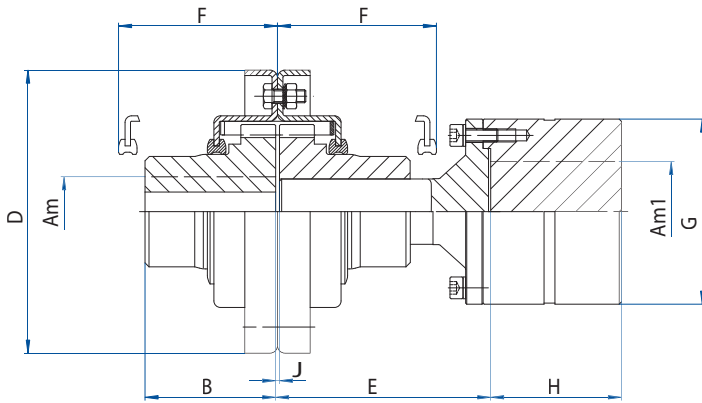

F: Clearance for grid spring assembly and removal

Item	Designation
1	Winflex
2	Spacer
3	Screws
4	Rigid hub

SIZE	Z	000	00	0	1	2	5	9
Nominal Torque (Nm)	90	190	380	950	1900	3800	8500	12500
Am keyway	28	38	55	55	80	110	105	130
Am1 keyway	42	48	65	65	90	120	120	140
B*	T	50	60	60	60	80	110	110
	TL	-	-	-	110	110	110	170
D	92	130	158	165	200	250	265	307
F	58	59	59	78	78	79	125	125
G	75	85	107	107	156	185	185	230
J ₀ ^{+0,3}	3	3	4	4	4	4	4	4
H	60 80	60 110	80 110 140	80 110 140	110 140	140 170 210	140 170 210	170 210
E	80 to 160	80 to 160	80 to 200	100 to 180	110 to 190	140 to 210	160 to 210	180 to 250

Weight (kg) type T Being average for E and H	4	7	13	14.5	33.7	58.5	69	97
J (kgm ²)** Being average for E and H	0.0025	0.0075	0.0225	0.025	0.1	0.3	0.3	0.85
Max speed (Rpm)	Without balance	3600	3600	3600	3000	2400	1700	1500
	Dynamically balanced	-	-	-	3600	3600	3600	3000

*Types: T = 2 short hubs
TL = 1 short hub + 1 long hub
**Solid hub type T

The contents of this bulletin are subject to change without notice.

Type TDF for Disc Brake Application

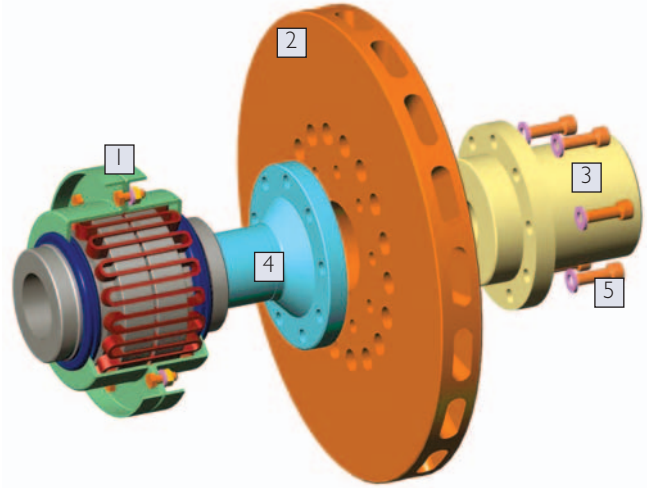
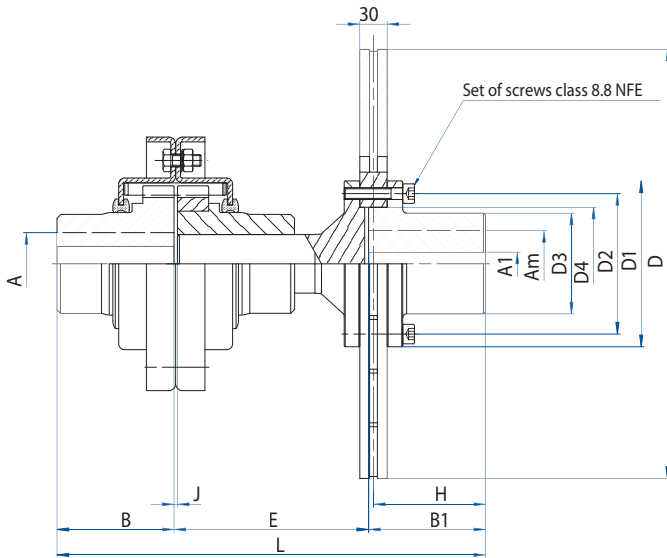

Coupling with ventilated disc brake,
Designed to permit mounting and dismounting of the disc
Without necessity of moving connecting machines.

Item	Designation
1	Winflex
2	Disc brake
3	Rigid hub
4	Spacer
5	Screws

SIZE	0			1		2				5					9			16	
D	315	355	395	395	445	445	495	550	625	495	550	625	705	795	625	705	795	795	
Maximum Peak Torque (Nm)	950			1900		3800				8500					12500			24000	
Am	Keyway fitting	55	55	55	80	80	110	110	110	105	105	105	105	105	130	130	130	180	
	Shrink fit	45	45	45	60	60	100	100	100	90	90	90	90	90	110	110	110	170	
AmI	Keyway fitting	55	70	75	75	80	80	110	110	120	110	110	120	135	150	120	135	150	150
	Shrink fit	50	60	70	70	70	70	100	100	105	100	100	105	120	135	105	120	135	135
A1	-	-	-	-	-	-	30	30	30	30	30	30	30	30	30	30	30	30	30
B	60	60	60	80	80	80	80	80	80	110	110	110	110	110	110	110	110	110	130
B1	107	107	107	107	140	140	140	140	140	140	140	140	140	140	140	140	140	140	140
D1	124	145	165	165	175	175	218	218	238	218	218	238	268	300	238	268	300	300	
D2	105	125	140	140	146	146	190	190	205	190	190	205	230	260	205	230	260	260	
D3	82	100	110	110	112	112	155	155	168	155	155	168	190	216	168	190	216	216	
D4	85	105	115	115	120	120	160	160	170	160	160	170	195	220	170	195	220	220	
Number of Screws	9	9	9	9	12	12	12	12	12	12	12	12	12	12	12	12	12	12	
Set screws diameter	M10	M12	M14	M14	M16	M16	M18	M18	M20	M18	M18	M20	M22	M24	M20	M22	M24	M24	
Tightening Torque (Nm)	49	86	135	135	210	210	290	290	410	290	290	410	550	710	410	550	710	710	
$J_0^{+0,3}$	4	4	4	4	4	4	4	4	4	4	4	4	4	4	4	4	4	4	
E	117	115	115	115	115	115	127	127	127	162	162	162	162	167	169	169	169	187	
L	284	282	282	302	335	335	347	347	347	412	412	412	412	417	419	419	419	457	
X	102	102	102	102	135	135	135	135	135	135	135	135	135	135	135	135	135	13	

Weight (kg) with Rough bore*	15.2	18.2	20.5	29.7	31.7	44	61.5	61.5	67.5	74	74	80	90	105	103	111	125	187
J Solid hub type T (kgm³)*	0.02	0.03	0.04	0.07	0.08	0.17	0.27	0.27	0.33	0.33	0.33	0.40	0.51	0.70	0.65	0.76	0.95	2

Check that Maximum Peak Torque is larger than installation Peak Torque

* Without Disc

The contents of this bulletin are subject to change without notice.

Type BSAT - BSATL - BSATL2

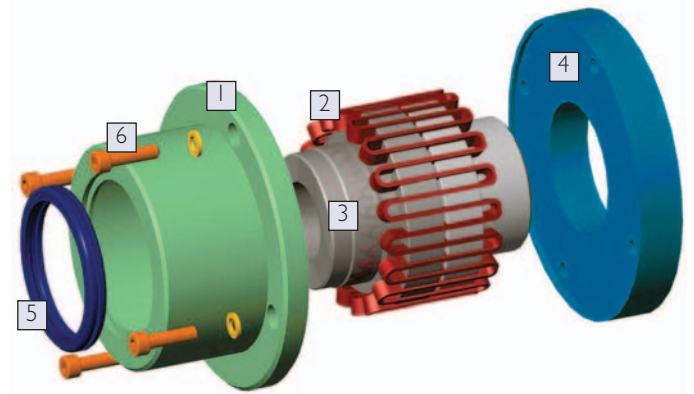
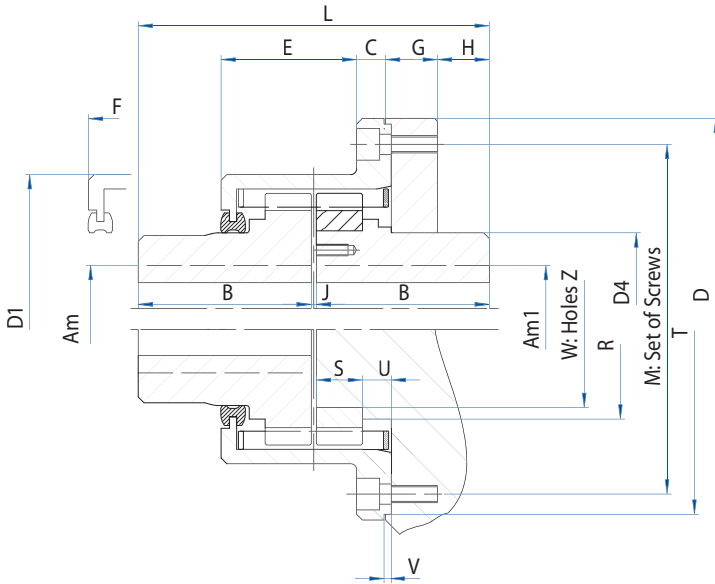

Item	Designation
1	Cover
2	Spring
3	Hub
4	Flange
5	Seal
6	Screws

Suitable mounting of pulley or flywheel
 F: Clearance for grid spring assembly and removal

SIZE		0	1	2	5	9	16	28	43	70	95
Nominal Torque (Nm)		950	1900	3800	8500	12500	24000	48000	70000	120000	160000
Am	Keyway	55	80	110	105	130	180	230	230	230	270
Am1	Keyway	50	75	110	100	120	180	230	230	230	270
Am shrink fit for hub without flange		45	60	100	90	110	170	200	220	220	250
B	T	60	80	80	110	110	130	155	180	200	230
	TL,TL2	110	110	110	170	195	195	225	260	280	300
C		13.5	13	13	19	22	27	11	10	11	13
D		170	205	250	286	340	425	515	616	630	700
D1		127	162	209	222	266	344	440	536	545	615
D4		75	109	157	145	182	250	326	326	326	376
E		62	62,5	62,5	102	99	94	112	113	188	187
F		120	120	120	187	187	187	187	187	314	315
J		2 ⁺² _{-0,5}	3 ⁺¹ ₋₁	3 ⁺¹ ₋₁	3 ⁺¹ ₋₁	3 ⁺¹ ₋₁	3 ⁺¹ ₋₁	4 ⁺² ₋₂	4 ⁺² ₋₂	4 ⁺² ₋₂	4 ⁺² ₋₂
G		25.5	28	28	33	35	38	38	45	50	55
H		19.9	19.9	19.9	22.7	20.7	37.7	62.7	80.7	58.7	83.7
L		122	163	163	223	223	263	314	364	404	464
M		144	178	225	248	296	376	468	565	578	648
Set screws diameters		4xM8	6xM8	6xM8	6xM10	6xM12	6xM12	8xM12	12xM12	12xM12	12xM12
R		-	-	-	153 ^{+0,1} _{-0,1}	191 ^{+0,1} _{-0,1}	263 ^{+0,1} _{-0,1}	350 ^{+0,1} _{-0,1}	445 ^{+0,1} _{-0,1}	410 ^{+0,2} _{-0,2}	480 ^{+0,2} _{-0,2}
S		-	-	-	35	35	35	35	35	57	57
T (H7)		-	-	-	276	330	415	505	605	620	690
U		-	-	-	21.5	21.5	21.5	20.5	20.5	36.5	36.5
V		-	-	-	3	3	3	3	3	4	4
W (t7)		-	-	-	120	165	240	335	430	390	460
Z		-	-	-	4xM12	4xM12	6xM12	6xM14	8xM14	8xM16	8xM18

BSAT Weight (kg) With Rough bore		12	22	39	56	85	157	290	411	518	721
BSAT J (kgm ²) Solid hub		0.0325	0.0825	0.2125	0.4	0.825	2.45	6.75	13.5	18.75	31.75
Maximum speed (Rpm)	Without balance	3600	2800	2000	2000	1700	1300	1000	800	800	700
	Dynamically balanced	5000	5000	4500	4200	3600	3000	2400	1800	1800	1500

The contents of this bulletin are subject to change without notice.

Type CPF with Brake Drum

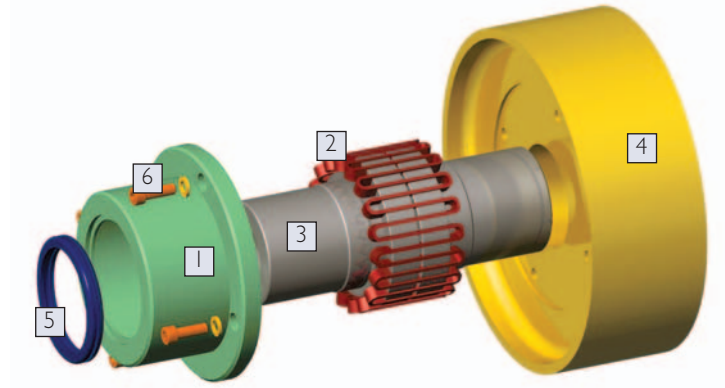
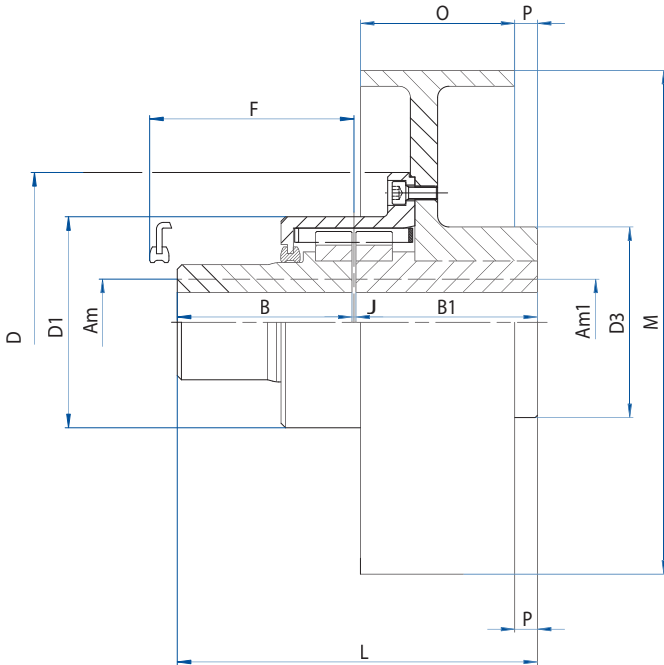

Item	Designation
1	Cover
2	Spring
3	Hub
4	Brake Drum
5	Seal
6	Screws

F: Clearance for grid spring assembly and removal

SIZE		0		1		2		5		9			16			28	
Nominal Torque (Nm)		950		1900		3800		8500		12500			24000			48000	
Am	Keyway	55		80		110		105		130			180			230	
AmI	Keyway	50		70		110		100		115			150			220	
Am	Shrink Fit ♦	45		60		100		90		100			170			200	
B		110		110		110		170		195			195			225	
B1		110		110		110		170		195 210 250			210 250 300			250 300	
D		170		205		250		286		340			425			515	
D1		127		162		209		222		266			344			440	
D3		120		160		225		220		185			255			330	
F		120		120		120		187		187			187			190	
J		2 ⁺² _{-0,5}		3 ⁺¹ ₋₁		3 ⁺¹ ₋₁		3 ⁺¹ ₋₁		3 ⁺¹ ₋₁			3 ⁺¹ ₋₁			4 ⁺² ₋₂	
L		222		223		223		343		393 408 448			408 448 498			479 529	
M		200 250		250		250 350		350 450		450 530 600			530 600 750			600 750	
O		80 90		90		90 130		130 170		170 195 210			195 210 230			210 230	
P		0 0		0		12 0		40 0		25 15 40			15 40 70			40 70	

Weight (kg) ♦		25	33	42	61	76	87	116	169	198	242	272	322	421	462	588
J (kgm ²) with brake and solid hub		0.09	0.192	0.235	0.41	0.785	0.857	2.015	3.07	5.45	2.08	6.9	10	22.5	14.1	27.7
Maximum speed (Rpm)	Without balance	2400	1910	1910	1910	1360	1360	1060	1060	900	635	900	635	510	635	510

♦ Valid only for bore opposite to the brake.

♦ Total weight with rough bore and inclusive of the brake drum.

The contents of this bulletin are subject to change without notice.

Type S

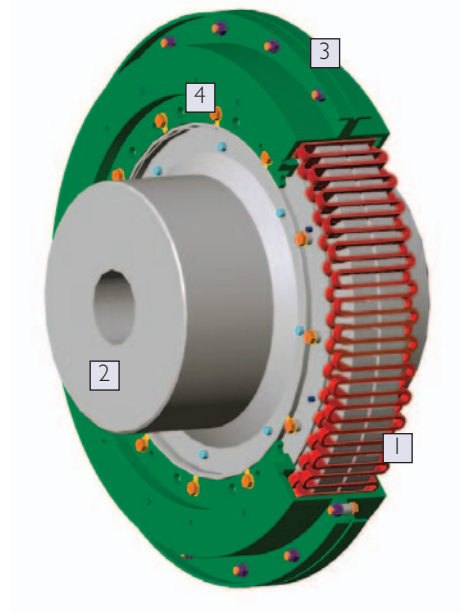
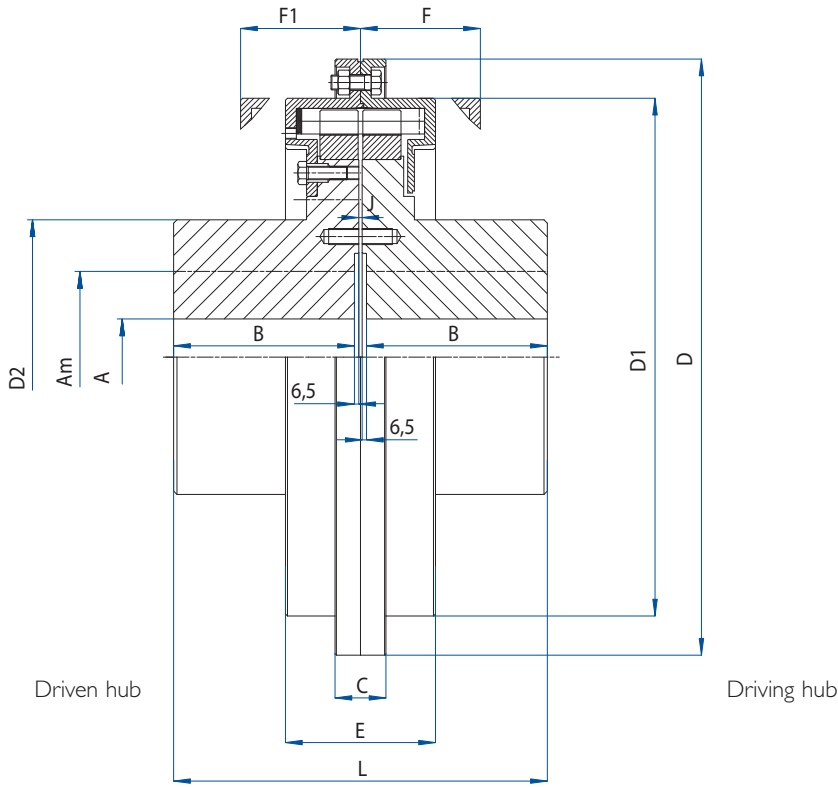

Item	Designation
1	Grid
2	Hub
3	Cover
4	Bolts & screws

F & F1: Clearance for grid spring assembly and removal





SIZE	150	220	300	380	480
Nominal Torque (Nm)	270 000	400 000	540 000	700 000	800 000
Am	270	300	340	370	390
A (Rough bore)	120	165	180	180	180
B	270	300	340	370	400
C	76	80	92	92	92
D1	773	910	1050	1195	1220
D2	410	450	550	600	620
E	224	220	224	224	265
F	210	210	210	210	250
F1	215	215	215	215	255
J	4 ⁺² ₋₂	5 ⁺² ₋₃	5 ⁺² ₋₃	5 ⁺² ₋₃	6 ⁺² ₋₃
L	557	618	698	758	819
2 Withdrawal holes diameter	360 M24	380 M24	450 M30	500 M30	-

Weight (kg) with Rough bore	990	1260	1860	2390	2830
Weight of grease (kg)	12	22	27	30	45
J (kgm ²) Solid hub	64.5	110.75	206.25	340	415.75
Max speed (Rpm)	Without balance	500	400	370	320
	Dynamically balanced	950	800	700	600

Am: Maximum permissible bore corresponding to the hub dimensions **which may be increased if it is required.**

The contents of this bulletin are subject to change without notice.

Miscellaneous

SIZE		Z	000	00	0	1	2	5	9	16	28	43	70	95
	Weight (kg) Rough bore (mm)	0.69 -	1.35 -	2.7 -	3 -	7.2 -	13.8 -	17.8 30	27 30	56 60	113 75	150 85	182 95	263 105
	Weight (kg) Rough bore (mm)	- -	- -	- -	4.8 -	9.5 -	18.6 -	25.4 30	44 30	80 60	158 75	200 85	231 95	320 105
	COMPLETE GRID Weight (kg) segments Layers	0.075 1 1	0.105 1 1	0.140 1 1	0.480 2 1	0.620 2 1	0.840 2 1	2.6 4 2	3.7 4 2	5 4 2	6.5 6 2	8 8 2	22 8 2	25 8 2
	Weight (kg) Kit (cover, bolts, screws and seals)	0.38	0.85	1.07	1.32	1.6	2.5	4	5	7.8	12.2	19	23	28
	Weight (kg) Grease	0.06	0.09	0.11	0.17	0.3	0.35	1	1.3	1.6	1.8	2	4.5	8

Special grease

- **Long life grease (*) HPLD 9000**
- Extreme-pressure grease, unleaded high temperature NLGI 1 lithium soap-base grease. Made with a high viscosity oil and an extremely effective, heavy-duty additive package.
- Formulated to provide low bleed properties critical to modern couplings as well as high temperature stability.
- **Maintains its excellent performance characteristics in ambient temperatures up to 110°C.**

(*) based on average period of 40 000 H. without greasing.



The contents of this bulletin are subject to change without notice.

Flexible couplings



Winflex DG



Flexacier 9000



Flexident Senior



Flexident Z



Tonoflex*

**This product can only be supplied out of European Union when mounted on gearboxes.*



SALES DEPARTMENT

36, avenue de l'Europe – Immeuble l'Etendard
BP 43 – 78142 VELIZY Cedex – FRANCE

Tel.: +33 (0) 1 34 63 12 24 – Fax: +33 (0) 1 34 63 12 12

E-mail : contact@cmdgears.com

HEAD OFFICE – FACTORY

539, avenue du Cateau – 59400 CAMBRAI - FRANCE

Tel.: +33 (0) 3 27 73 53 11 – Fax: +33 (0) 3 27 78 36 99

www.cmd-couplings.com
www.cmd-gears.com